

Constant Voltage & Constant Current LED Power Supply

SLT6-350ILs
SLT6-700ILs



Product description:

This series was designed for compromise between an attractive price and high performance, which meets SELV standard of preventing electric shock. Protection of open circuit, short circuit, over load and over temperature increased safety in processing. Low standby power consumption complies with ERP directives. Optimized electric circuit design brings cost-effectiveness.



Standards:

EN61347-1
EN61347-2-13
EN61547
EN55015
EN61000-3-2
EN61000-3-3
EN62384
EN62493

Characteristics:

- Compact dimensions
- Independent use design
- Compatible with constant current and constant voltage function (350mA and 700mA model)
- SELV output (<60V)
- Low output ripple current $\leq \pm 10\%$
- Fast start-up time $\leq 0.5s$
- No load power consumption $\leq 0.3W$
- Open circuit, short circuit, over load and over temperature protection
- Auto restart after fault conditions removal
- High efficiency 79%
- ECO design, comply with ERP directives

Specifications:

Model		SLT6-350ILs	SLT6-700ILs	
Output	turn on time(S)	≤0.5	≤0.5	
	output current(mA)	350	700	
	CC	output current tolerance ^①	+/-8%	+/-8%
		ripple current(mA)	35(Ip-p)	140(Ip-p)
		working voltage range(V)	7.5-21	3-9
		Max. output voltage(V)	25	13
		output votage (V)	24	12
	CV	output voltage tolerance ^①	+/-1.5%	+/-1.5%
		ripple voltage(mV)	350(Vp-p)	250(Vp-p)
		working current range(A)	0-0.3	0-0.5
		dimming interface	No	
dimming range	n/a			
Input	rated supply voltage(Vac)	220-240	220-240	
	voltage range(Vac)	198-264	198-264	
	line frequency(Hz)	50/60	50/60	
	input current(mA)	90	80	
	efficiency ^②	78.6%	74.5%	
	power factor ^②	0.55	0.55	
	inrush current(Ipk)	7A/180us	7A/180us	
Protection	over voltage protection	YES	YES	
	short circuit protection	YES	YES	
	over temperature protection	YES	YES	
	automatic restart	YES	YES	
	over load protection	YES	YES	
	surge capacity	L-N: 500V	L-N: 500V	
Ambient and Life	Ta(°C)	-20...+45		
	Tc max.(°C)	80		
	Storage Temperature(°C)	-30...80		
	ambient humidity range	5%...85%RH, Not condensing		
	nominal life-time(hrs)	30'000@Tc=80°C		
Other	weight(g)	39		
	dimensions (LxWxH)(mm)	68x35x20		
	casing material	Plastic		
	housing colour	White		
	type of protection	IP20		
	protection class	CLASSII		
Note	<p>1. Tolerance:includes set up tolerance, line regulation and load regulation. 2. Tested at full load,230Vac.Refer to"Power Factor" and "EFFICIENT"curve graphs. 3. All parameters NOT specially mentioned are measured at nominal voltage input, rated load and 25 of ambient temperature. 4. The power supply is considered as a component that will be operated in combination with final equipment. Since EMC performance will be affected by the complete installation, the final equipment manufacturers must re-qualify EMC Directive on the complete installation again."</p>			

Dimensions(mm):

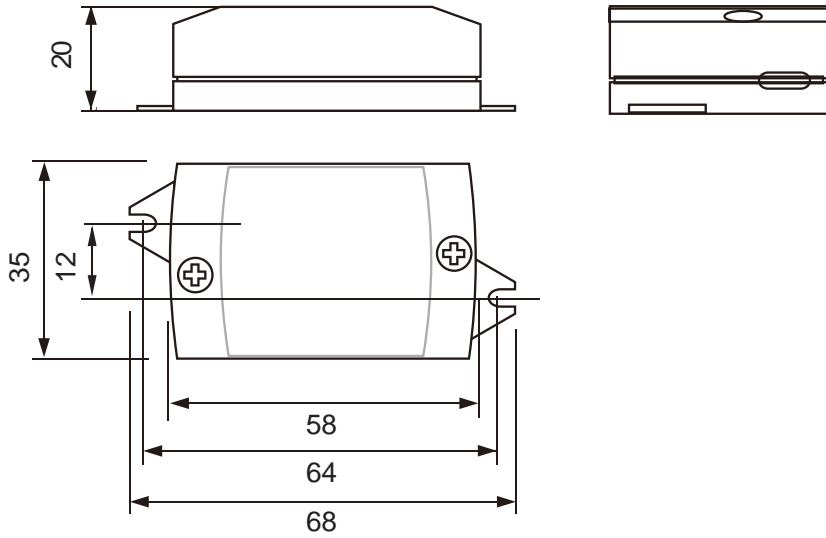

Wiring diagram:

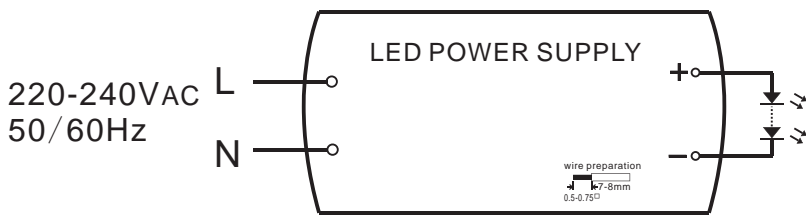

Electrical curves:

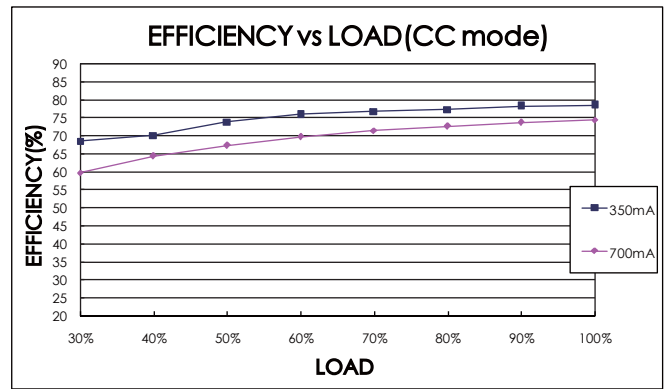
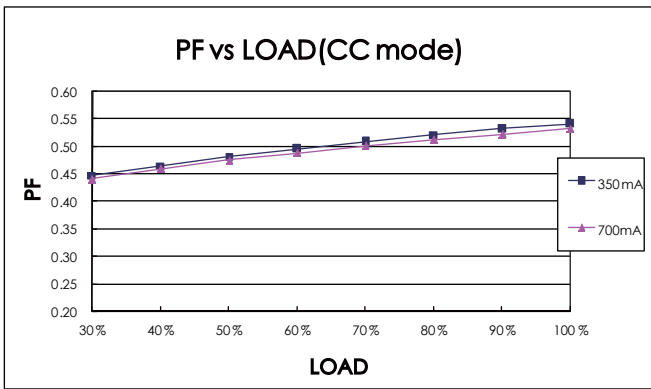
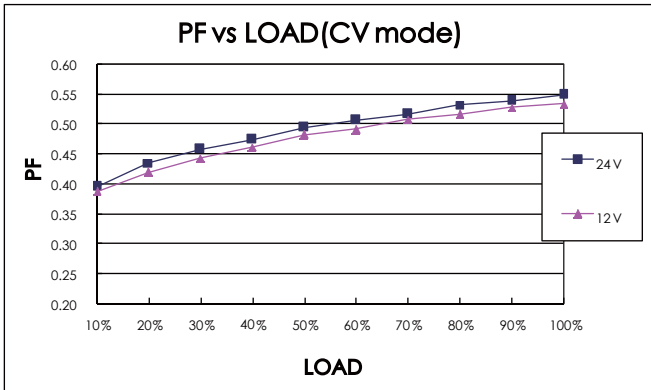

note
 For constant current power supply,"LOAD" means the percentage of the maximum rated output voltage.
 For constant voltage power supply,"LOAD" means the percentage of the maximum rated output current.



MCBS information:

Miniature circuit breaker Model Model	B10	B13	B16	B20	C10	C13	C16	C20
SLT6-350ILs	68	91	113	142	118	142	193	236
SLT6-700ILs	68	91	113	142	118	142	193	236

Order information:

Order.No.	Model	Carton quantity(pcs)	Carton dimension(mm)	G.W./CTN(kg)
1001-660221-0131	SLT6-350ILs	200	425x315x275	9.7
1001-660222-0131	SLT6-700ILs	200	425x315x275	9.7

Sales & Technical Support:**SELF Electronics Co.,Ltd.(Headquarters)**

Add: No. 1345 JuXian Road, Ningbo Hi Tech Park, Ningbo, China 315103
 Phone: +86-574-2880-5765, +86-574-2880-5658 (for English assistance)
 +86-574-2880-5678 (for Chinese assistance)
 Fax: +86-574-28805656
 E-mail: sales@self-electronics.com
<http://www.self-electronics.com>

Self Electronics Co.,Ltd.,Shenzhen Office

Add: Room2007, Xinglang Xuan, Xinghemingju, Fuming Rd.,
 Futian District, Shenzhen
 Tel: +86-755-8355-8850
 Fax: +86-755-8355-8840
 E-mail: szsales@self-electronics.com

SELF Electronics Germany GmbH

August-Horch-Str. 7, 51149 Cologne
 Phone: +492203-18501-0
 Fax: 492203-18501-199
 E-mail: saleseu@self-electronics.com

*Due to continuous improvements and innovations, specifications are subjected to change without notice.